

技术特性/Specifications:

额定电压 Rated voltage: 50V AC, DC
 额定电流 Rated current: 1A AC, DC
 接触电阻 Contact resistance: 20mΩ max
 绝缘电阻 Insulation resistance: 100MΩ min
 耐压 Withstand voltage: 250V AC/minute
 环境温度 Ambient temperature: -25°C~+85°C
 适用线规 Wire range: AWG#32~#28

PC电路板布局和组件布局 PC board layout and Assembly layout

□ Assembly layout (装配布局)

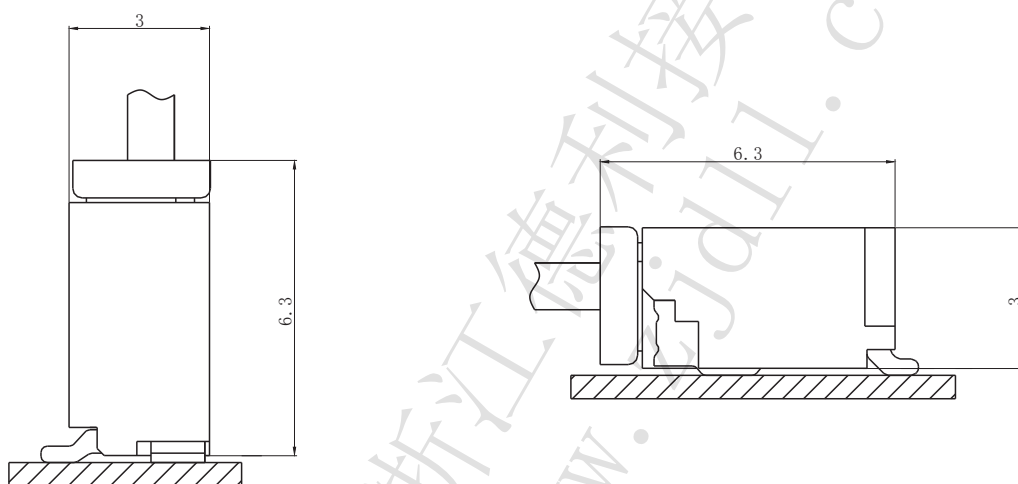

上图为连接器安装侧观察图
 Notes: The above figure is the figure viewed from the connector mounting side.

DL10002-T (501330-T)

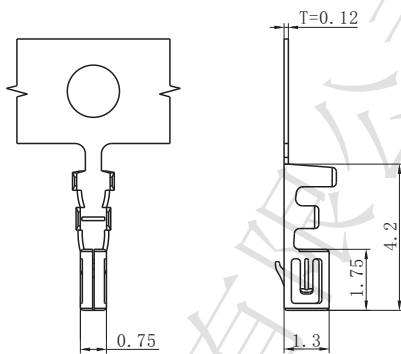

Model No. (型号)	Applicable wire (适用线规)			Material (材料)	Plating (电镀)	Qty/reel (数量/盘)
	mm ²	AWG#	Insulation O.D. (绝缘外径mm)			
DL10002-T (501330-T)	0.032~0.08	32~28	φ 0.4~0.8	Phosphor bronze (磷青铜)	Tin Plated (镀锡)	15000

符合RoHS标准
RoHS compliance
注：镀金产品请联系DLL
Note: Contact DLL for gold-plated products.

DL10002-2-5Y (501330-2-5Y)

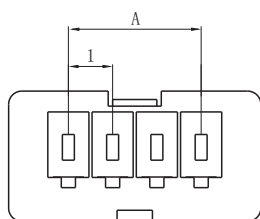
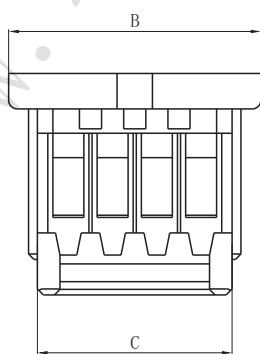

Circuits (电路)	Dimensions (尺寸mm)		
	A	B	C
2	1.00	3.70	2.40
3	2.00	4.70	3.40
4	3.00	5.70	4.40
5	4.00	6.70	5.40

Material (材料)
Housing (胶壳): Nylon (尼龙) UL94- V0 (2)

符合RoHS标准
RoHS compliance

DL10002-6-15Y (501330-6-15Y)

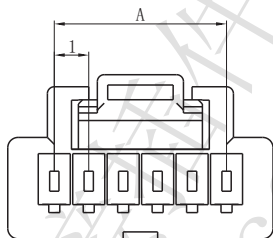
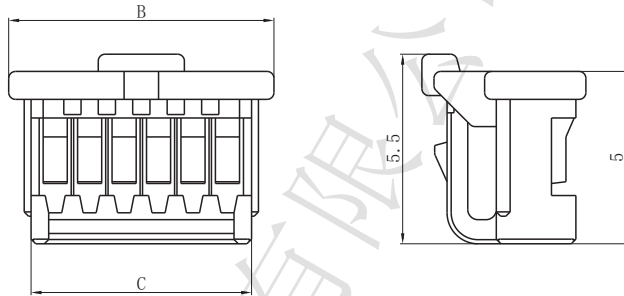

Circuits (电路)	Dimensions (尺寸mm)		
	A	B	C
6	5.00	7.70	6.40
7	6.00	8.70	7.40
8	7.00	9.70	8.40
9	8.00	10.70	9.40
10	9.00	11.70	10.40
11	10.00	12.70	11.40
12	11.00	13.70	12.40
13	12.00	14.70	13.40
14	13.00	15.70	14.40
15	14.00	16.70	15.40

Material (材料)

Housing (胶壳): Nylon (尼龙) UL94- V0 (2)

符合RoHS标准
RoHS compliance

DL10002-AB (501330-AB)

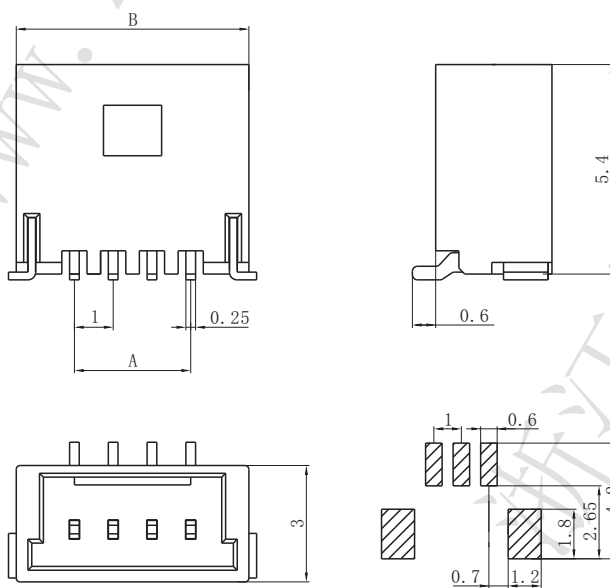

Circuits (电路)	Dimensions (尺寸mm)	
	A	B
2	1.00	4.00
3	2.00	5.00
4	3.00	6.00
5	4.00	7.00
6	5.00	8.00
7	6.00	9.00
8	7.00	10.00
9	8.00	11.00
10	9.00	12.00
11	10.00	13.00
12	11.00	14.00
13	12.00	15.00
14	13.00	16.00
15	14.00	17.00

Material (材料)

Housing (胶壳): LCP UL94-V0

Wafer (接触件): Phosphor bronze (磷青铜) / Tin plated (镀锡)

Solder tabs (焊片): Brass (黄铜) / Tin plated (镀锡)

符合RoHS标准
RoHS compliance
注: 镀金产品请联系DLL
Note: Contact DLL for gold-plated products.

□ DL10002-AWB (501330-AWB)

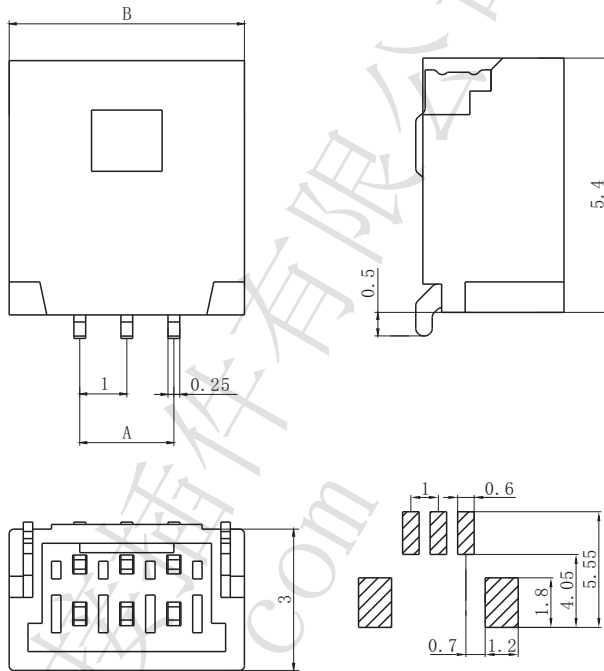

Circuits (电路)	Dimensions (尺寸mm)	
	A	B
2	1.00	4.00
3	2.00	5.00
4	3.00	6.00
5	4.00	7.00
6	5.00	8.00
7	6.00	9.00
8	7.00	10.00
9	8.00	11.00
10	9.00	12.00
11	10.00	13.00
12	11.00	14.00
13	12.00	15.00
14	13.00	16.00
15	14.00	17.00

Material (材料)

Housing (胶壳): LCP UL94-V0

Wafer (接触件): Phosphor bronze (磷青铜) / Tin plated (镀锡)

Solder tabs (焊片): Brass (黄铜) / Tin plated (镀锡)

符合RoHS标准

RoHS compliance

注: 镀金产品请联系DLL

Note: Contact DLL for gold-plated products.